

Silca System on timber deck joists - Top Mount Balustrade

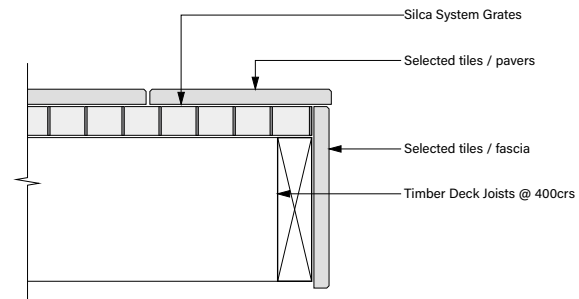

Silca System on timber deck joists - Fascia Edge

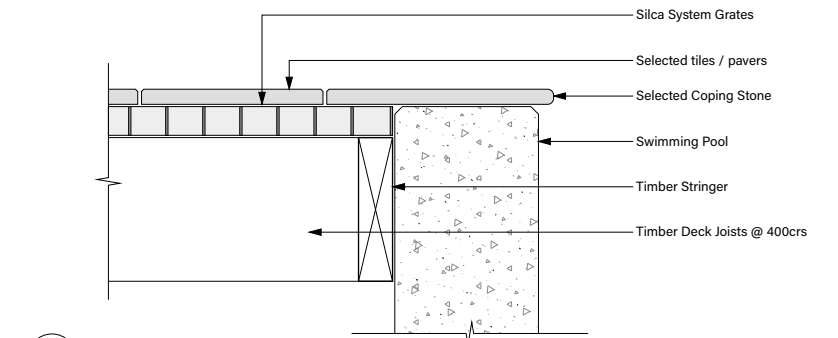

Silca System on timber deck joists - Pool Edge

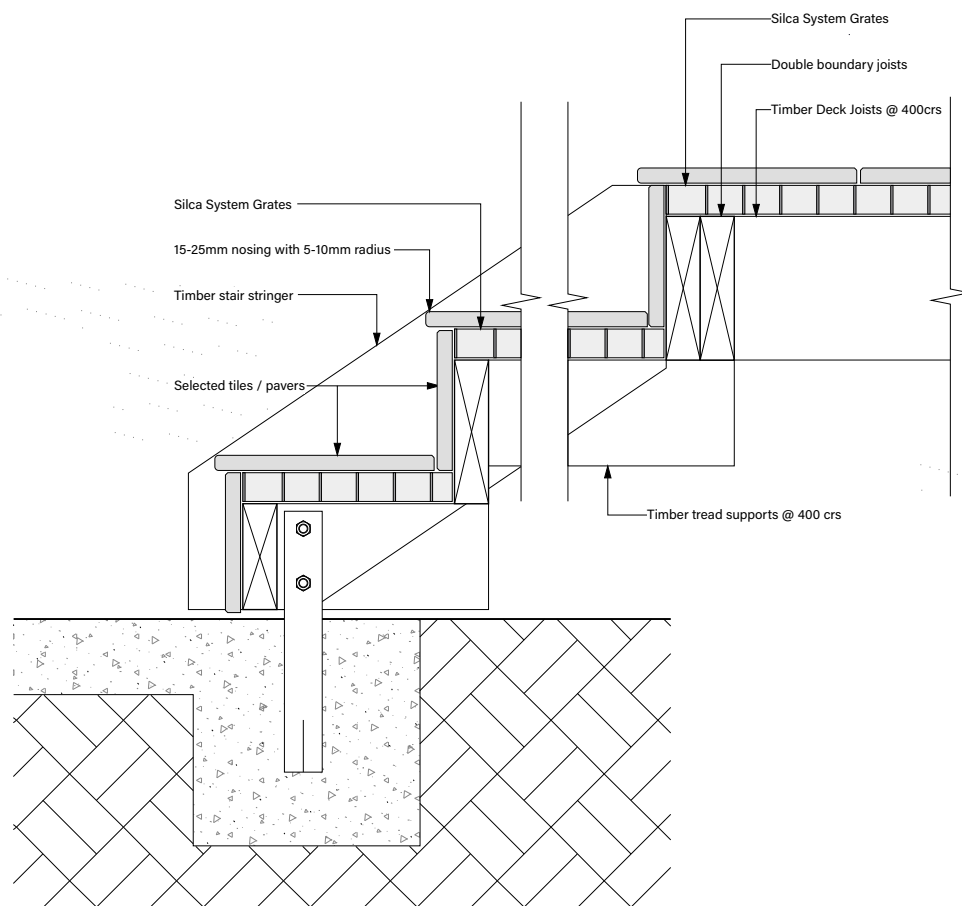

Silca System on timber steps (private or common stairway)

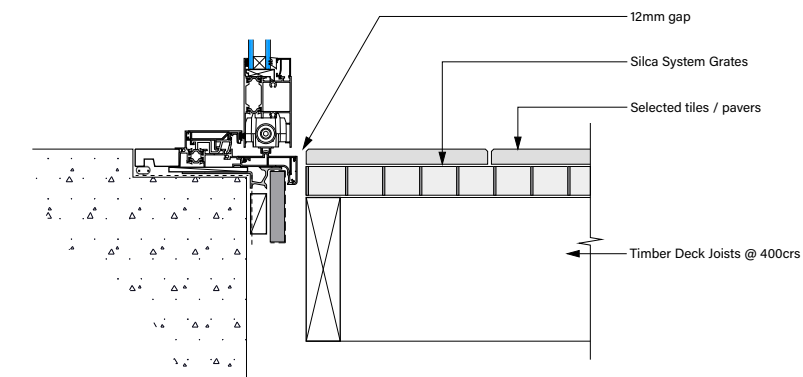

Silca System on timber deck joists at door threshold

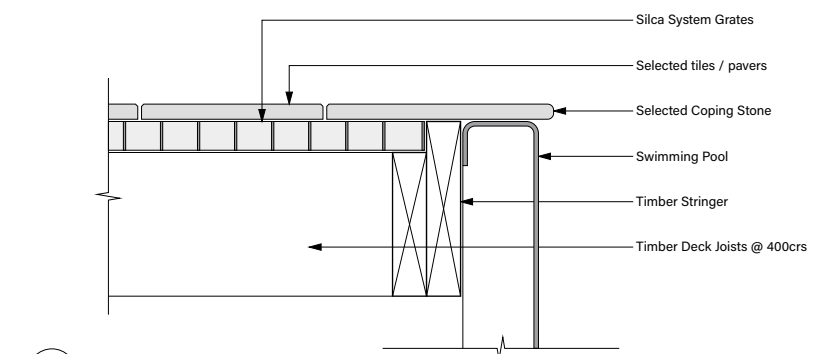

Silca System on timber deck joists - Pool Edge

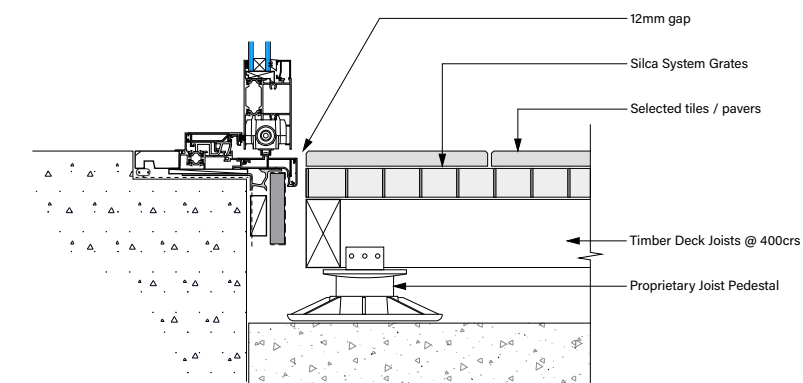

Silca System on timber deck joists and joist pedestals

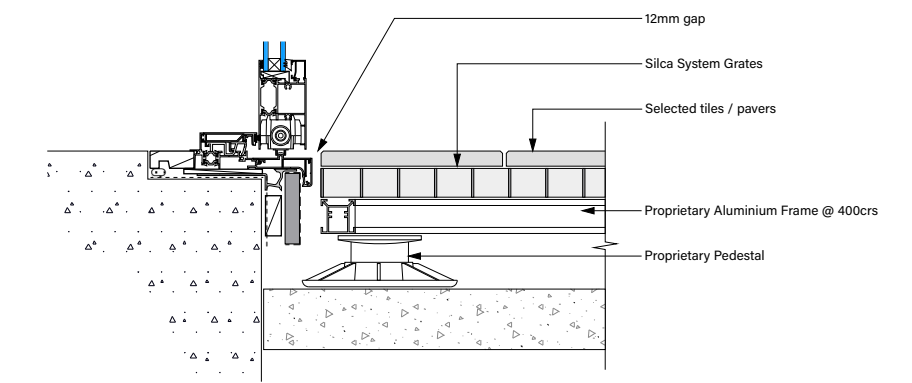

Silca System on aluminium frame and pedestals



The use of this document is subject to the following terms and conditions:
 Dimensions must not be scaled from this drawing. All dimensions must be verified on-site prior to construction. Any discrepancies in this document or related documents must be reported to the designer before commencing construction. Users shall rely solely on the professional judgment and skill of installers to determine the document's appropriateness and verify the accuracy of the data contained herein. Construction must comply with Silca System's installation guidelines, local building codes, national standards, statutory regulations, and local authority requirements, which take precedence over details in this document.
 For structures built over a waterproof membrane system, the installer is solely responsible for ensuring the membrane manufacturer's warranty remains valid.
 This drawing is the sole property of Merx Pacific Ltd. / Silca System NZ and must not be copied, reproduced, retained, or disclosed to any unauthorized party, in whole or in part, without prior written permission.
 Merx Pacific Ltd. assumes no liability for improper use, installation, or design modifications not expressly approved. Users acknowledge that Merx Pacific Ltd. is not responsible for any specific use or application of the material provided.

Merx Pacific Ltd. All rights reserved. No part of this publication may be reproduced, distributed, or transmitted in any form or by any means, including photocopying, recording, or other electronic or mechanical methods, without prior written permission from the publisher, except for brief quotations used in critical reviews or permitted non-commercial uses under copyright law. If in doubt about any details, contact Silca System NZ at info@silcasystem.co.nz or visit www.silcasystem.co.nz for clarification.

Note: Read in conjunction with the Silca System Installation Guide and website: silcasystem.co.nz - Selected tiles / pavers 14 - 60mm thick. 20mm shown. - Spot glue fix tiles with recommended adhesives to Silca Grate and timber. - Install tiles / pavers with gaps for drainage.

- Silca Grates connected with Silca Lock connectors (2 per side) into designated slots (3.3 per grate). - Fix Silca Grates to timber joist with 10g 75mm stainless steel, countersunk screws (x6 per grate). - Fix Silca Grates to aluminium with 10g 60mm stainless steel, countersunk, self drilling screws (x6 per grate). - Proprietary Pedestals to be self leveling and adjustable (where required).